

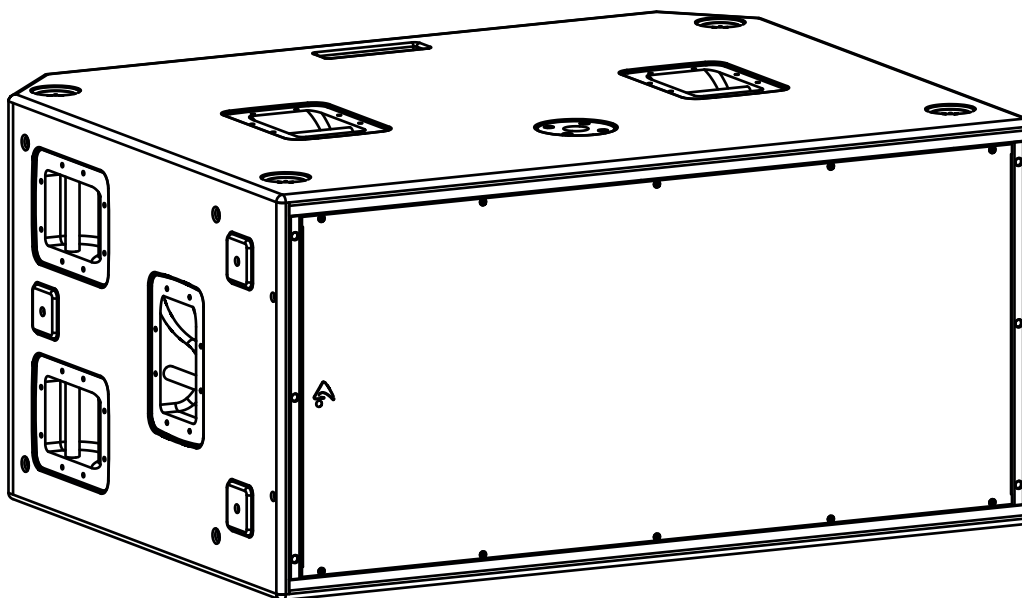

SW218XAV2

active subwoofer



USER MANUAL

revision 2024-04-29





IMPORTANT SAFETY INSTRUCTIONS

Watch for these symbols:



The lightning flash with arrowhead symbol within an equilateral triangle is intended to alert the user to the presence of uninsulated “dangerous voltage” within the product’s enclosure, that may be of sufficient magnitude to constitute a risk of electric shock to persons.



The exclamation point within an equilateral triangle is intended to alert the user to the presence of important operating and maintenance (servicing) instructions in the literature accompanying the appliance.

1. Read these instructions.
2. Keep these instructions.
3. Heed all warnings.
4. Follow all instructions.
5. Do not use this apparatus near water.
6. Clean only with dry cloth.
7. Do not block any ventilation openings. Install in accordance with the manufacturer’s instructions.
8. Do not install near any heat sources such as radiators, heat registers, stoves, or other apparatus (including amplifiers) that produce heat.
9. Do not defeat the safety purpose of the polarized or grounding-type plug. A polarized plug has two blades with one wider than the other. A grounding-type plug has two blades and a third grounding prong. The wide blade or the third prong are provided for your safety. If the provided plug does not fit into your outlet, consult an electrician for replacement of the obsolete outlet.
10. Protect the power cord from being walked on or pinched, particularly at plugs, convenience receptacles, and the point where they exit from the apparatus.
11. Only use attachments/accessories specified by the manufacturer.
12. Use only with the cart, stand, tripod, bracket, or table specified by the manufacturer, or sold with the apparatus. When a cart is used, use caution when moving the cart/apparatus combination to avoid injury from tip-over.
13. Unplug this apparatus during lightning storms or when unused for long periods of time.
14. Refer all servicing to qualified service personnel. Servicing is required when the apparatus has been damaged in any way, such as power supply cord or plug is damaged, liquid has been spilled or objects have fallen into the apparatus, the apparatus has been exposed to rain or moisture, does not operate normally, or has been dropped.
15. Warning: to reduce the risk of fire or electric shock, do not expose this apparatus to rain or moisture.
16. Do not expose this equipment to dripping or splashing and ensure that no objects filled with liquids, such as vases, are placed on the equipment.
17. To completely disconnect this apparatus from the ac mains, disconnect the power supply cord plug from the ac receptacle.
18. The mains plug of the power supply cord shall remain readily operable.
19. This apparatus contains potentially lethal voltages. To prevent electric shock or hazard, do not remove the chassis, input module or ac input covers. No user serviceable parts inside. Refer servicing to qualified service personnel.
20. The loudspeakers covered by this manual are not intended for high moisture outdoor environments. Moisture can damage the speaker cone and surround and cause corrosion of electrical contacts and metal parts. Avoid exposing the speakers to direct moisture.
21. Keep loudspeakers out of extended or intense direct sunlight. The driver suspension will prematurely dry out and finished surfaces may be degraded by long-term exposure to intense ultra-violet (UV) light.
22. The loudspeakers can generate considerable energy. When placed on a slippery surface such as polished wood or linoleum, the speaker may move due to its acoustical energy output.
23. Precautions should be taken to assure that the speaker does not fall off a stage or table on which it is placed.
24. The loudspeakers are easily capable of generating sound pressure levels (SPL) sufficient to cause permanent hearing damage to performers, production crew and audience members. Caution should be taken to avoid prolonged exposure to SPL in excess of 90 dB.

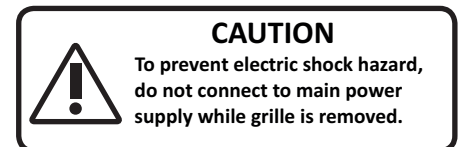

This marking shown on the product or its literature, indicates that it should not be disposed with other household wastes at the end of its working life. To prevent possible harm to the environment or human health from uncontrolled waste disposal, please separate this from other types of wastes and recycle it responsibly to promote the sustainable reuse of material resources. Household users should contact either the retailer where they purchased this product, or their local government office, for details of where and how they can take this item for environmentally safe recycling. Business users should contact their supplier and check the terms and conditions of the purchase contract. This product should not be mixed with other commercial wastes for disposal.



FEDERAL COMMUNICATIONS COMMISSION (FCC) STATEMENT

This equipment has been tested and found to comply with the limits for a Class A digital device, pursuant to part 15 of the FCC Rules. These limits are designed to provide reasonable protection against harmful interference when the equipment is operated in a commercial environment. This equipment generates, uses, and can radiate radio frequency energy and, if not installed and used in accordance with the instruction manual, may cause harmful interference to radio communications.

Operation of this equipment in a residential area is likely to cause harmful interference in which case the user will be required to correct the interference at their own expense.

This device complies with Part 15 of the FCC rules. Operation is subject to the following two conditions:

- (1) this device may not cause harmful interference, and
- (2) this device must accept any interference received, including interference that may cause undesired operation.

DECLARATION OF CONFORMITY

C E The product is in compliance with:
EMC Directive 2014/30/EU, LVD Directive 2014/35/EU, RoHS Directive 2011/65/EU and 2015/863/EU, WEEE Directive 2012/19/EU.

EN 55032 (CISPR 32) STATEMENT

Warning: This equipment is compliant with Class A of CISPR 32. In a residential environment this equipment may cause radio interference. Under the EM disturbance, the ratio of signal-noise will be changed above 10 dB.

UK CA The product is in compliance with:
S.I. 2016/1091 Electromagnetic Compatibility Regulations 2016, S.I. 2016/1101 Electrical Equipment (Safety) Regulations 2016, S.I. 2012/3032 The Restriction of the Use of Certain Hazardous Substances in Electrical and Electronic Equipment Regulations 2012.

CISPR 32 STATEMENT

Warning: This equipment is compliant with Class A of CISPR 32. In a residential environment this equipment may cause radio interference. Under the EM disturbance, the ratio of signal-noise will be changed above 10 dB.

LIMITED WARRANTY

Proel warrants all materials, workmanship and proper operation of this product for a period of two years from the original date of purchase. If any defects are found in the materials or workmanship or if the product fails to function properly during the applicable warranty period, the owner should inform about these defects the dealer or the distributor, providing receipt or invoice of date of purchase and defect detailed description. This warranty does not extend to damage resulting from improper installation, misuse, neglect or abuse. Proel S.p.A. will verify damage on returned units, and when the unit has been properly used and warranty is still valid, then the unit will be replaced or repaired. Proel S.p.A. is not responsible for any "direct damage" or "indirect damage" caused by product defectiveness.

- This unit package has been submitted to ISTA 1A integrity tests. We suggest you control the unit conditions immediately after unpacking it.
- If any damage is found, immediately advise the dealer. Keep all unit packaging parts to allow inspection.
- Proel is not responsible for any damage that occurs during shipment.
- Products are sold "delivered ex warehouse" and shipment is at charge and risk of the buyer.
- Possible damages to unit should be immediately notified to forwarder. Each complaint for package tampered with should be done within eight days from product receipt.

CONDITIONS OF USE

Proel do not accept any liability for damage caused to third parties due to improper installation, use of non-original spare parts, lack of maintenance, tampering or improper use of this product, including disregard of acceptable and applicable safety standards. Proel strongly recommends that this loudspeaker cabinet be suspended taking into consideration all current National, Federal, State and Local regulations. The product must be installed by qualified personal. Please contact the manufacturer for further information.



INDEX

INTRODUCTION	4
TECHNICAL SPECIFICATION	4
MECHANICAL DRAWING	5
OPTIONAL ACCESSORIES	5
SPARE PARTS	5
I/O AND CONTROL OPERATIONS	6
MAINS~ IN.	6
MAINS~ OUT.	6
ON	6
PROT	6
SIGN LIMIT	6
INPUT	6

LINK	6
GND LIFT	6
NETWORK IN/OUT	6
TERMINATE	6
PRESET BUTTON	7
PRONET AX	8
PREDICTION SOFTWARE: EASE FOCUS 3	9
CARDIOID PRESET	10

INTRODUCTION

The SW218XAV2 subwoofer is designed to deliver high quality low frequency reproduction where very high output is a key requirement, together with well defined deep bass response and fast transient response. The very high output makes it ideal for concert touring and festival applications requiring high levels of low frequency response, such as hard rock and electronic music, and for top level dance music clubs.

The SW218XAV2 is a very high quality powered subwoofer system featuring some of the most advanced technologies for low frequency reproduction. Its unique and innovative design is based on a configuration that can be defined as Manifolded Transmission Line. It uses manifolding of the front side of the cones to maximize the mutual coupling between the two drivers, while loading the back of the cone with a large-size transmission line that has the function to create a transmission path from the back of the transducers to the front. This innovative configuration does not use any large resonant cavity to load the speaker in order to get the lower octave and this reduces significantly pressure decay time inside the enclosure, with large advantages in terms of definition both at the lowest end and the upper bass. At the same time, it doesn't use very long transmission line paths as well. Its working principle is an hybrid combination between a short transmission line and an overdamped reflex load. Moreover, the maximization of the mutual coupling between the drivers increase the fastness of the transient response while maximizing the overall energy efficiency as well.

The SW218XAV2 subwoofer system is equipped with two high power 18" (460mm) transducers capable of very long excursion (up to 30mm peak-to-peak) and featuring a large displacement suspension system. These transducers use Tetracoil technology, where two different, axially separated magnetic gaps and two inside-outside 100 mm (4") diameter voice coils are wound on the same former and suspended evenly in the two magnetic gaps. This creates an equivalent voice coil diameter greater than 6", resulting in a larger heat dissipation area for and increased power handling. Additional key advantages of the Tetracoil technology are also minimized distortion and a very symmetric and flat inductance curve. Cones are made of very high-stiffness fiberglass reinforced paper, featuring also invisible water repellent treatment.

TECHNICAL SPECIFICATION

SYSTEM		Network protocol	CANBUS
System's Acoustic Principle	Manifolded Transmission Line	Amplifier Type	Class D amplifier with SMPS & PFC
Frequency response (±3 dB)	30 Hz – 92 Hz (Processed)	Output Power	2000 W + 2000 W
Maximum Peak SPL @ 1m	143 dB	Mains Voltage Range (Vac)	100 - 240 V~ ±10% 50/60 Hz
TRANSDUCERS		Consumption*	600 W (nominal) 2000 W (max)
Type	Two 18" (460 mm), 4" (100 mm) VC 8Ω	IN / OUT Connectors	Neutrik XLR-M / XLR-F
Cone	Water repellent, epoxy coated plates	IN / OUT Network Connectors	ETHERCON® (NE8FAV)
Voice Coil Type	100mm (4in) Tetracoil dual voice coil, equivalent to a single coil diameter larger than 152mm (>6in)	Mains Connector	PowerCon® (NAC3MPXXA)
Suspension	Ultra linear suspension behavior	Mains Link Connector	PowerCon® (NAC3MPXXB)
ELECTRICAL		Cooling	Variable speed DC fan
Input Impedance	20 kΩ balanced	ENCLOSURE & CONSTRUCTION	
Input Sensitivity	+4 dBu / 1.25 V	Width	1215 mm (47.87")
Signal Processing	CORE2 processing, 40bit floating point SHARC DSP, 24 bit AD/DA converters	Height	590 mm (23.24")
Direct access Controls	4 Presets: Standard, InfraSub, Cardioid, User. Network Termination, GND Link	Depth	950 mm (37.43")
Remote Controls	PRONET AX control software	Depth with Wheels	1078 mm (42.44")
		Enclosure material	15 mm, reinforced Phenolic Birch
		Paint	High resistance, water based paint
		Wheels	4 heavy-load 100 mm ø
		Transport	10 handles
		Net Weight	121.2 Kg (267.2 lbs.)

* Nominal consumption is measured with pink noise with a crest factor of 12 dB, this can be considered a standard music program.





MECHANICAL DRAWING

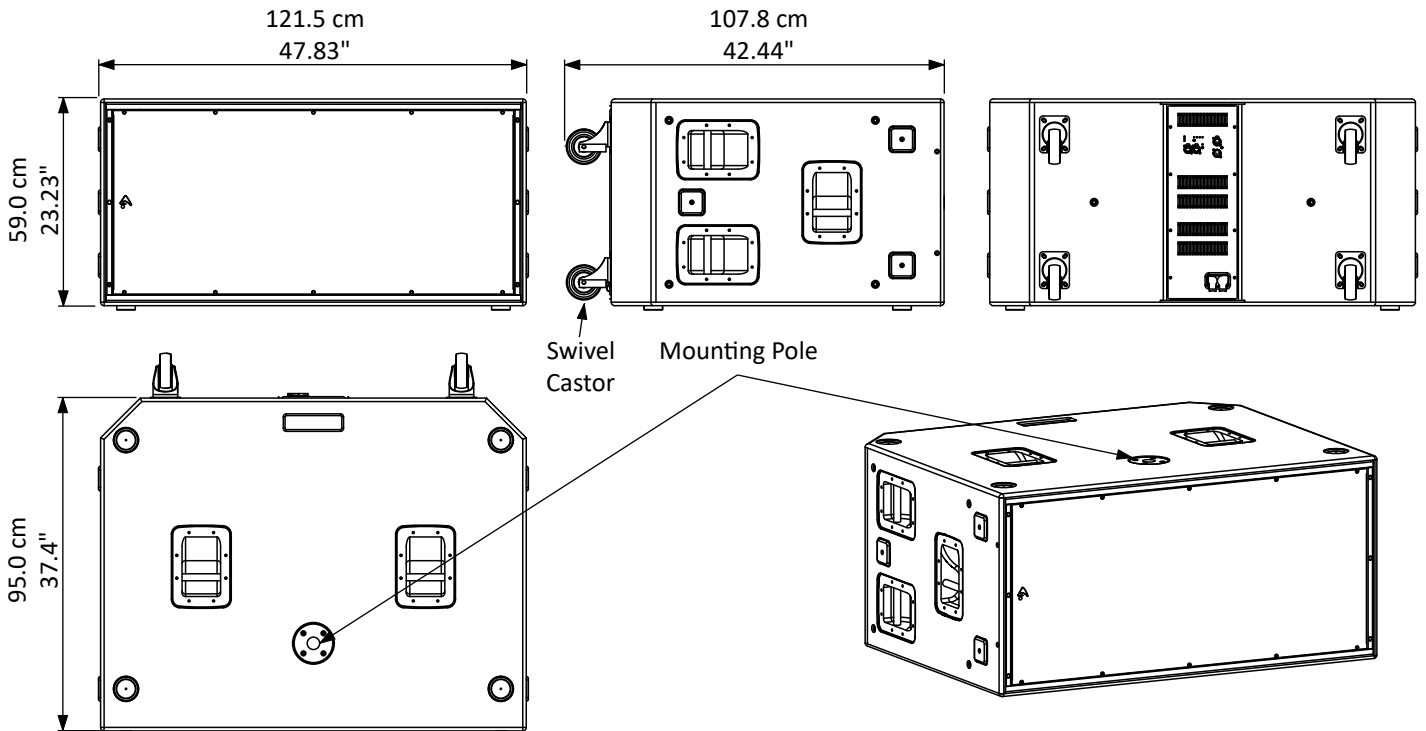

OPTIONAL ACCESSORIES

- NAC3FX-W-TOP-L** Neutrik Powercon® TRUE1 (for power in)*
- NAC3MX-W-TOP-L** Neutrik Powercon® TRUE1 (for power out)*
- HTLACA** Tool for tightening powerCON TRUE1*
- HTLACB** Tool for tightening powerCON TRUE1*
- NE8MC-B-1** Neutrik Ethercon PLUG
- USB2CANDV2** Dual Port PRONET AX network converter

see <http://www.axiomproaudio.com/> for detailed description and other available accessories.

*Note: See assembly instruction downloadable from NEUTRIK WEB site at: <http://www.neutrik.com/>

SPARE PARTS

- 91AMD SW218XV2** SW218XAV2 Amplifier module assembly
- NAC3PX-TOP** Neutrik Powercon® TRUE1 inlet-outlet
- SCNAC-04** Neutrik Rubber Sealing for NAC3PX
- 91DSPKT11** Input, Control and CORE2 DSP PCBA

- DHSS10M20** Sub-Speaker ø35mm 1-1.7m Pole with Handle and M20 screw
- KP210S** Sub-Speaker ø35mm 0.7-1.2m Pole with M20 screw
- COVEREDSW218** Padded cover for SW218/218X
- AVCAT5PROxx** Cat5e on cable drum, 30/50/75 m Length

- 91DALITEMOD4HV** Powersoft LITEMOD4HV amplifier module
- 98AXM218TLW8** 18" woofer - 4" Tetracoil® dual voice coil - 8 ohm
- AC103GS** 100 mm Swivel castor without brake



I/O AND CONTROL OPERATIONS

MAINS~ IN

Powercon® NAC3PX power inlet connector. To switch the amplifier on, insert the Powercon® connector and turn it clockwise into the ON position. To switch the amplifier off, pull back the switch on the connector and turn it counter-clockwise into the POWER OFF position.

MAINS~ OUT

Powercon® NAC3PX power outlet connector. This is connected in parallel with the MAINS~ IN.



WARNINGS:

- Connect no more than one subwoofer unit to the MAINS~ OUT connector.
- If you use the MAINS~ OUT turn on each subwoofer unit one at a time.
- In the case of product failure or fuse replacement, disconnect the unit completely from the mains power.
- Use a suitable power cable and mains plug to build the power cable, it must only be connected to a socket corresponding to the specifications indicated on the amplifier unit.
- See assembly instruction downloadable from NEUTRIK WEB site at: <http://www.neutrik.com/>

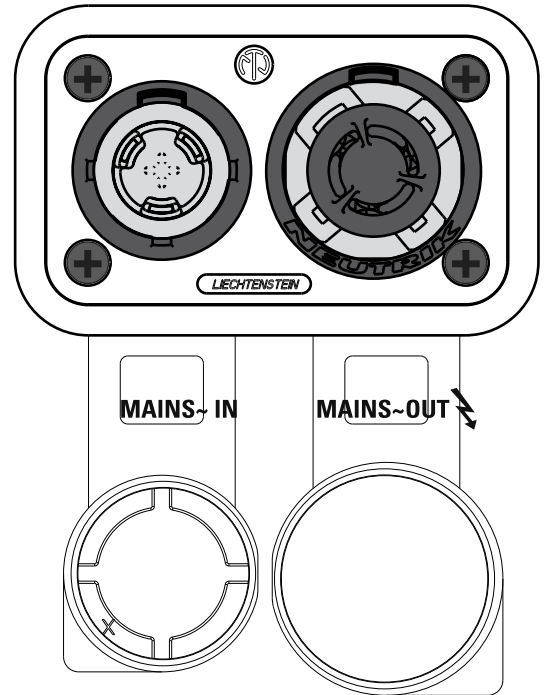

ON

This LED indicates power on status.

PROT

This red LED lights when the amplifier module is in protect mode for an internal fault and, consequently, the amplifier is muted.

SIGN LIMIT

This LED lights in green to indicate the presence of the signal and lights in red when an internal limiter reduces the input level.

INPUT

Audio signal input with locking XLR connector. It has a fully electronically balanced circuitry including AD conversion for the best S/N ratio and input headroom.

LINK

A direct connection from the input connector to link other speakers with same audio signal.

GND LIFT

This switch lift the ground of the balanced audio inputs from the earth-ground of the amplifier module.

NETWORK IN/OUT

These are a standard RJ45 CAT5 connectors (with optional NEUTRIK NE8MC RJ45 cable connector carrier), used for PRONET network transmission of remote control data over long distance or multiple unit applications.

TERMINATE

In a PRONET AX network the last loudspeaker device must be terminated (with an inner load resistance) especially in a long run cabling: press this switch if you want to terminate the unit.

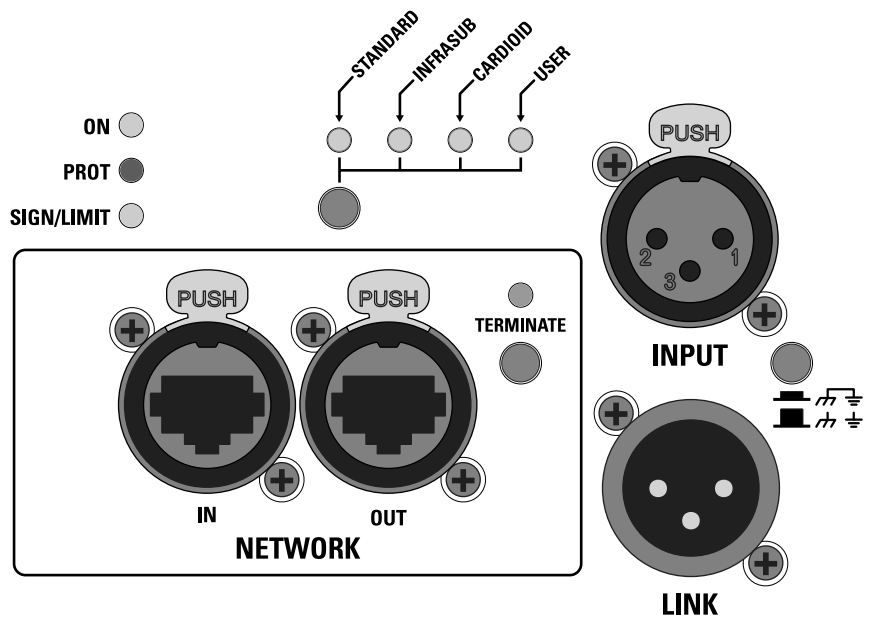



PRESET BUTTON

This button has two function:

1) Pressing it while powering on the unit:

ID ASSIGN The internal DSP assigns a new ID to the unit for the PRONET AX remote control operation. Each loudspeaker must have a unique ID to be visible in the PRONET AX network. When you assign a new ID, all the other loudspeakers with the ID already assigned must be ON and connected to the network.

2) Pressing it with the unit ON you can select the DSP PRESET. The selected PRESET is indicated by the corresponding LED:

STANDARD This PRESET is suitable for any application where low frequency reinforcement is required. It features a 90Hz cut off frequency and it can be used in almost any environment in combination with any vertical arrays.

INFRA This PRESET can be used when a deeper bass response is required (Note that when this preset is used the sound pressure level of the system is slightly reduced).
NOTE: INFRA and STANDARD PRESET must NOT be used together in close units.

CARDIOID This special PRESET, combined with the STANDARD PRESET, gives the advantage to reduce the low frequencies at the back of an array of three subs, in order to obtain a more comfortable level for the performers on the stage without losing level for the the audience in front of the array. The cardioid configuration is also useful in situation where you want to reduce the bass frequency feedback due to many microphones on stage, for example for acoustic and jazz ensemble, classic orchestra, musicals. Further in this manual you can find some example how to set up a cardioid array.

USER This PRESET corresponds to USER MEMORY no. 1 of the DSP and, as a factory setting, it's the same to STANDARD. If you want to modify it, you have to connect the unit to a PC, edit the parameters with PRONET AX software and save the PRESET into USER MEMORY no. 1.

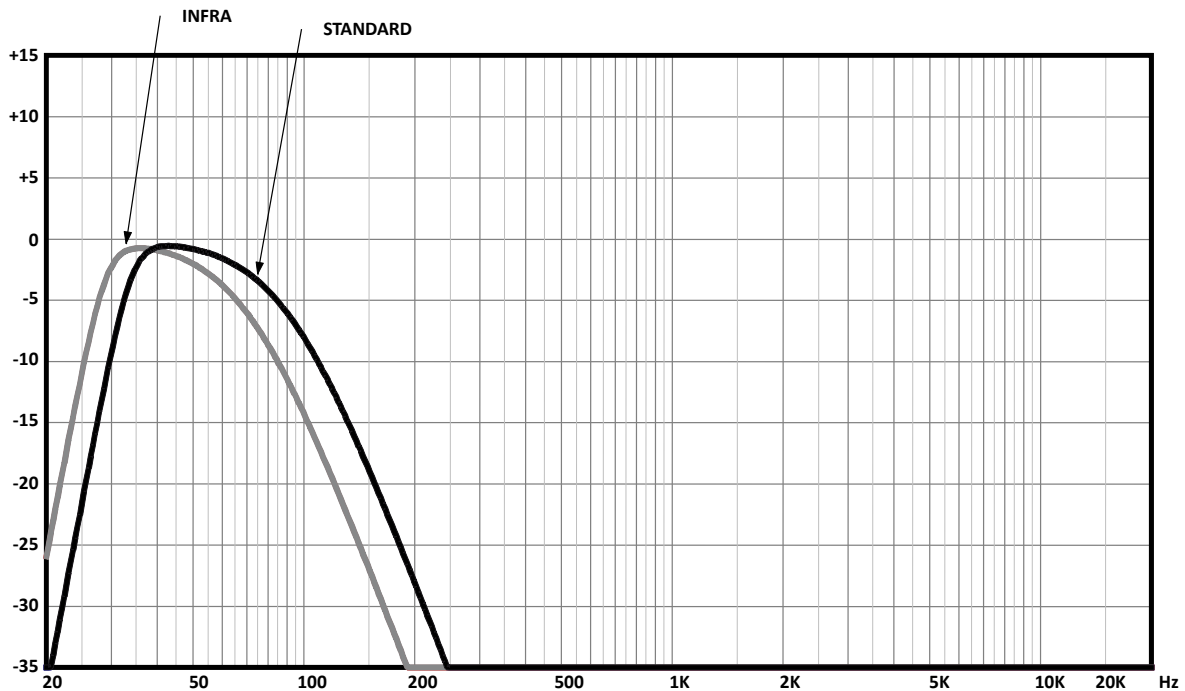

WARNING! CAREFULLY READ THE FOLLOWING INSTRUCTIONS AND CONDITION OF USE:

- This loudspeaker is designed exclusively for Professional audio applications. The product must be installed by qualified personal only.
- **SW218XAV2 is NOT designed to be suspended, use it in ground stack only.**
- Proel do not accept any liability for damage caused to third parties due to improper installation, lack of maintenance, tampering or improper use of this product, including disregard of acceptable and applicable safety standards.



PRONET AX

PRONET AX software has been developed in collaboration with sound engineers and sound designers, in order to offer an “easy-to-use” tool to setup and manage your audio system. With PRONET AX you can visualize signal levels, monitor internal status and edit all the parameters of each connected device.

Download the PRONET AX app registering on MY AXIOM at the website at <https://www.axiomproaudio.com/>.

The AXIOM active loudspeaker devices can be connected in a network and controlled by the PRONET AX software, for the network connection the **USB2CAND** (with 2-port) converter optional accessory is needed. PRONET AX network is based on a “bus-topology” connection, where the first device is connected to the network input connector of the second device, the second device network output is connected to the network input connector of the third device, and so on. To ensure a reliable communication the first and the last device of the “bus-topology” connection must be terminated. **This can be done by pressing the “TERMINATE” switch near the network connectors in the rear panel of the first and the last device.** For the network connections simple RJ45 cat.5 or cat.6 ethernet cables can be used (please don't confuse a ethernet network with a PRONET AX network these are completely different and must be fully separated also both use the same kind of cable).

EXAMPLE OF PRONET AX NETWORK WITH AX2010A AND SW218XA

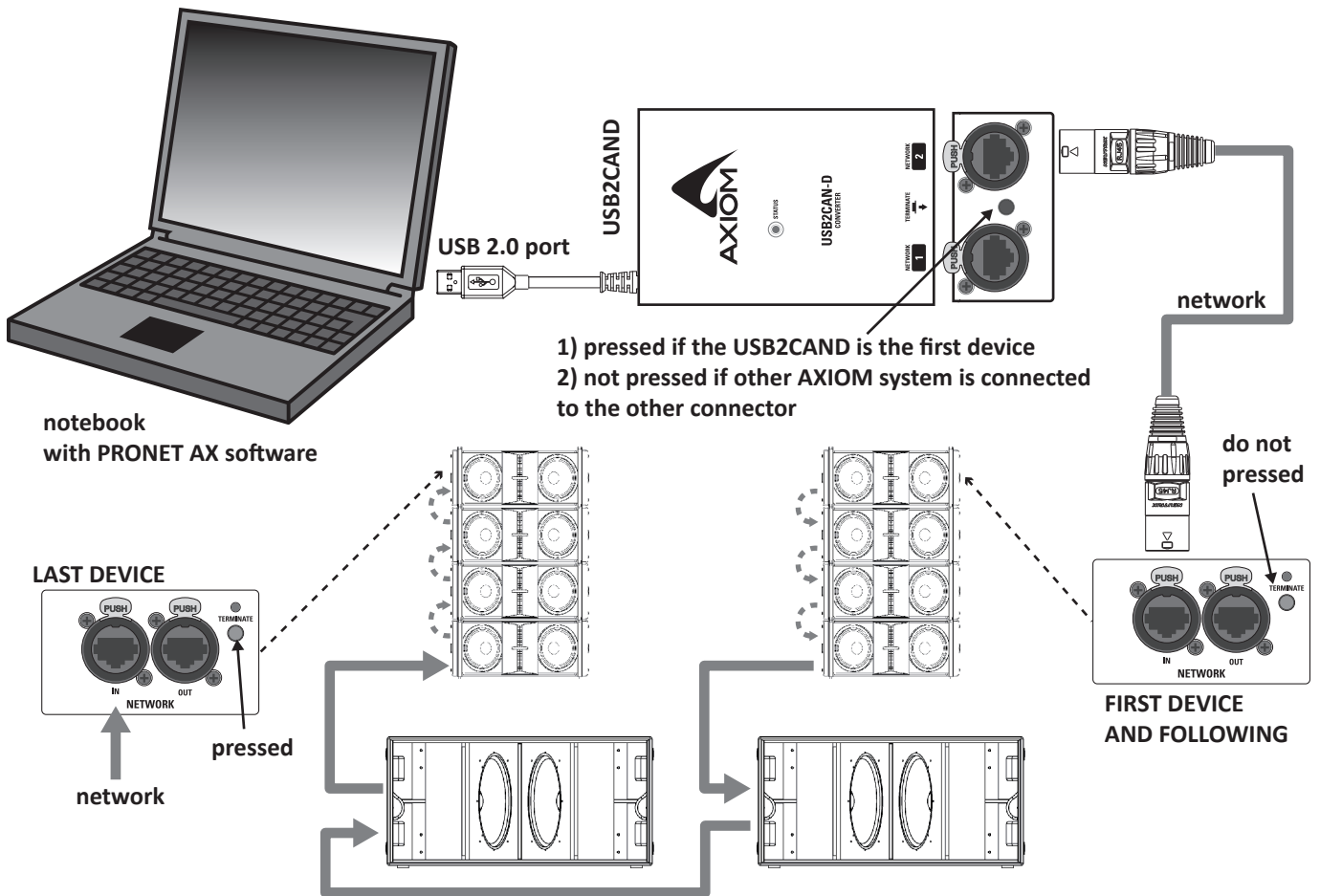



Assign the ID number

To work properly in a PRONET AX network each connected device must have a unique identifier number, called ID. By default the USB2CAN-D PC controller has ID=0 and there can be only one PC controller. Every other device connected must have its own unique ID equal or greater than 1: in the network cannot exist two devices with the same ID.

In order to correctly assign a new available ID to each device for working properly in a Pronet AX network, follow these instructions:

1. Switch off all the devices.
2. Connect them correctly to the network cables.
3. "TERMINATE" the end device in the network connection.
4. Switch on the first device keep pressed "PRESET" button on the control panel.
5. Leaving the previous device switched on, repeat the previous operation on the next device, until the latest device is turned on.

The "Assign ID" procedure for a device makes the internal network controller to perform two operations: reset the current ID; search the first free ID in the network, starting from ID=1. If no other devices are connected (and powered on), the controller assume ID=1, that is the first free ID, otherwise it searches the next one left free.

These operations ensure that every device has its own unique ID, if you need to add a new device to the network you simply repeat the operation of step 4. Every device maintains its ID also when it is turned-off, because the identifier is stored in the internal memory and it is cleared only by another "Assign ID" step, as explained above.



With the network made always of the same devices the assigning ID procedure must be executed only the first time the system is turned on.

For more detailed instruction about PRONET see the PRONET AX USER'S MANUAL included with the software.

PREDICTION SOFTWARE: EASE FOCUS 3

To aim correctly a complete system we suggests to use always the Aiming Software - EASE Focus 3:

The EASE Focus 3 Aiming Software is a 3D Acoustic Modelling Software that serves for the configuration and modelling of Line Arrays and conventional speakers close to reality. It only considers the direct field, created by the complex addition of the sound contributions of the individual loudspeakers or array components.

The design of EASE Focus is targeted at the end user. It allows the easy and quick prediction of the array performance in a given venue. The scientific base of EASE Focus stems from EASE, the professional electro- and room acoustic simulation software developed by AFMG Technologies GmbH. It is based on the EASE GLL loudspeaker data file required for its use. The GLL file contains the data that defines the Line Array with regard to its possible configurations as well as to its geometrical and acoustical properties.

Download the EASE Focus 3 app from the AXIOM website at <https://www.axiomproaudio.com/> clicking on downloads section of the product.

Use the menu option **Edit / Import System Definition File** to import the GLL file, the detailed instructions to use the program are located in the menu option **Help / User's Guide**.

Note: Some windows system can require the .NET Framework 4 that can be download from website at <https://focus.afmg.eu/>.

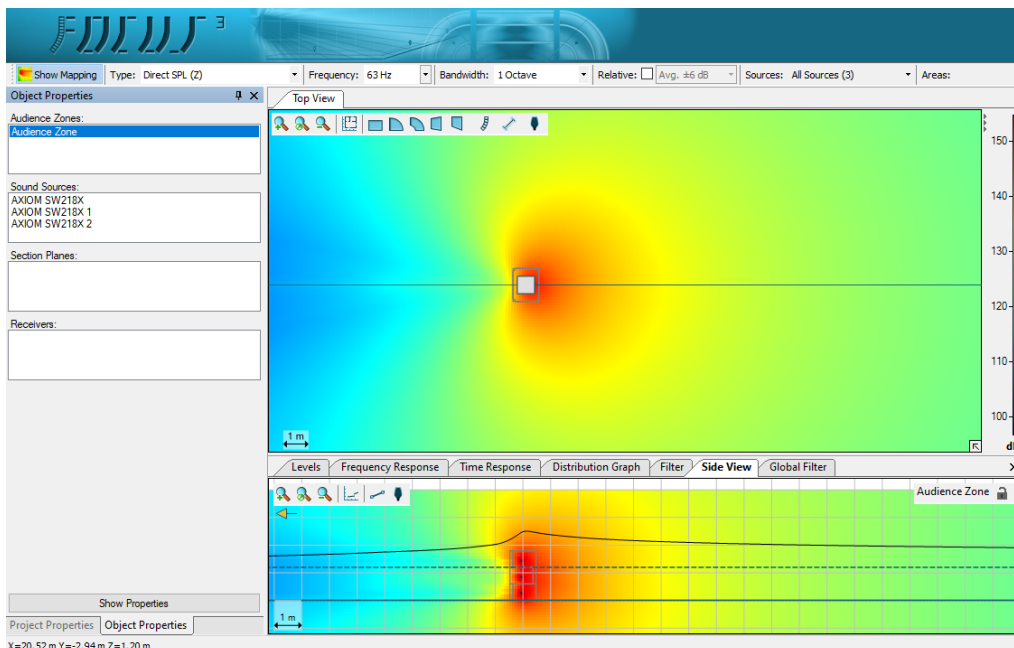

NOTE: in this figure is shown the result of an horizontal cardioid ground stack for the 63Hz octave.





CARDIOID PRESET

The cardioid preset must be used in a sub array of three SW218XAV2. Two boxes must be oriented towards the audience and one must be turned in the opposite direction (typically the box in the centre of the array). The bottom and the top boxes must have the STANDARD PRESET, the box in the middle must have the CARDIOID PRESET. The audio signal sent to all boxes is the same.

The CARDIOID PRESET has the same response of the STANDARD PRESET, but to obtain the maximum cancellation on the back side of the array it has the phase inverted and a proper level and delay setting.

The figure below shows two typical displacement of the array. The first with all the boxes in horizontal position for a total height of 1770 mm and a width of 1215 mm. The second one with all the boxes in vertical position for a total height of 1215 mm and a width of 1770 mm.

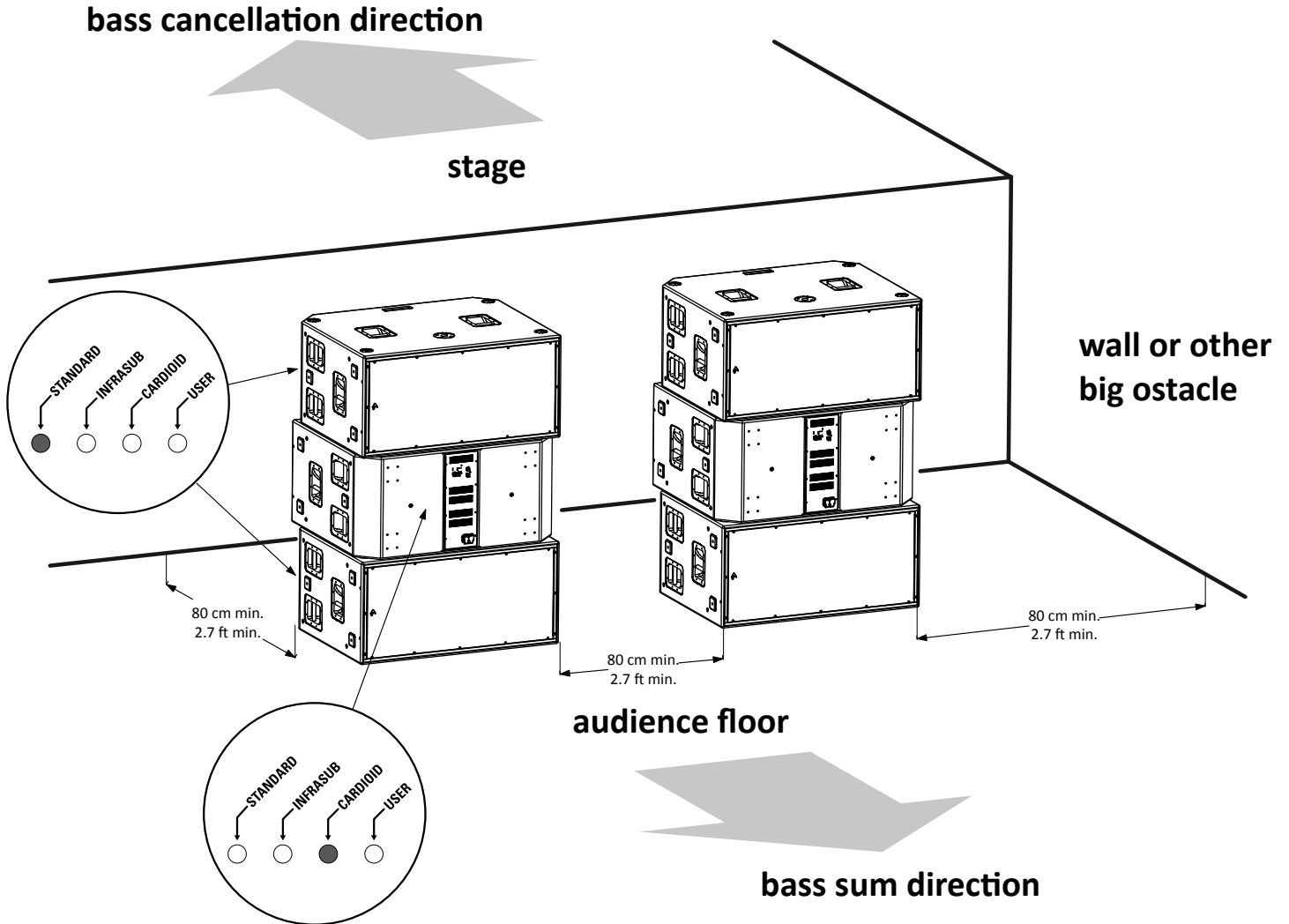

NOTES:

When placing the cardioid array keep a distance to walls or other obstacles of at least 80 cm (2.6 ft) in order not to affect the radiation of the reversed cabinet.

When placing multiple cardioid arrays keep a distance between them of at least 80 cm (2.6 ft) in order to maximize the combined radiation of whole arrays.

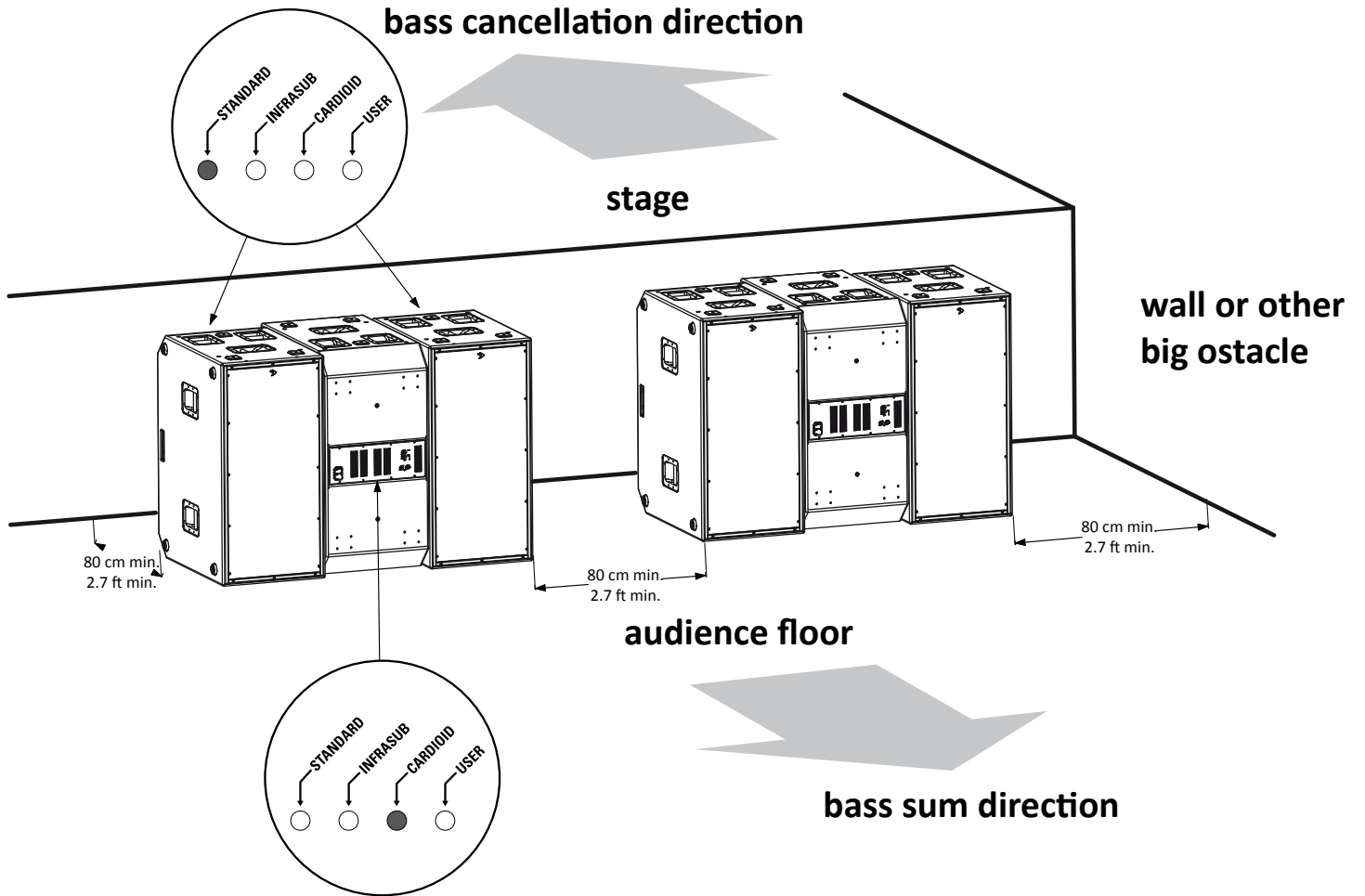

NOTES:

When placing the cardioid array keep a distance to walls or other obstacles of at least 80 cm (2.6 ft) in order not to affect the radiation of the reversed cabinet.

When placing multiple cardioid arrays keep a distance between them of at least 80 cm (2.6 ft) in order to maximize the combined radiation of whole arrays.



PROEL S.p.A. (World Headquarters) - Via alla Ruenia 37/43 - 64027 Sant'Omero (Te) - ITALY
Tel: +39 0861 81241 Fax: +39 0861 887862 www.axiomproaudio.com

